

Overview

The encoder type ME14-02 is a compact and rugged unit which is suitable for easy mounting. ME14-02 was originally designed to be used as a lit (with additional o-ring) for a meter and thereby removing risk of leakage through the bearings as well as saving overall costs. As a result of the integration with the meter, risk of fuel theft is reduced. The encoder is supplied with a matching neodymium magnet. ME14-02 is built for the fuel dispenser industry for use in automatic and semi-automatic petrol, LPG and diesel dispenser systems. The encoder is approved for use in environments where potentially explosive atmospheres can be expected. Two versions are available; one in raw aluminum and one in hard anodized (black) aluminum which is AdBlue tolerant.

Approval

The encoder ME14-02 has been tested and granted ATEX, IECEx and EMC approval. The Ex-approval is "II 2 G Ex db IIB T6 Gb" according to CENELEC EN60079-0 and EN60079-1. Furthermore, the ME14-02 has been tested to 75Bar.

Options

The ME14-02 is available in two different electrical versions;

Standard: Output any number of pulses per revolution from 8 to 1024. With the build in microprocessor we are able to generate any number of pulses per revolution less than 1024 and at the same time suppress backward pulses.

CAN-open: With an integrated temperature sensor, we are able to provide both the temperature and at the same time the volume per revolution. The fuel resistant cable can be customized regarding length, wire colour coding and cable end termination.

Accessories

Eltomatic has a growing range of brackets that support the use of ME14-02 to be mounted as a conventional shaft encoder.

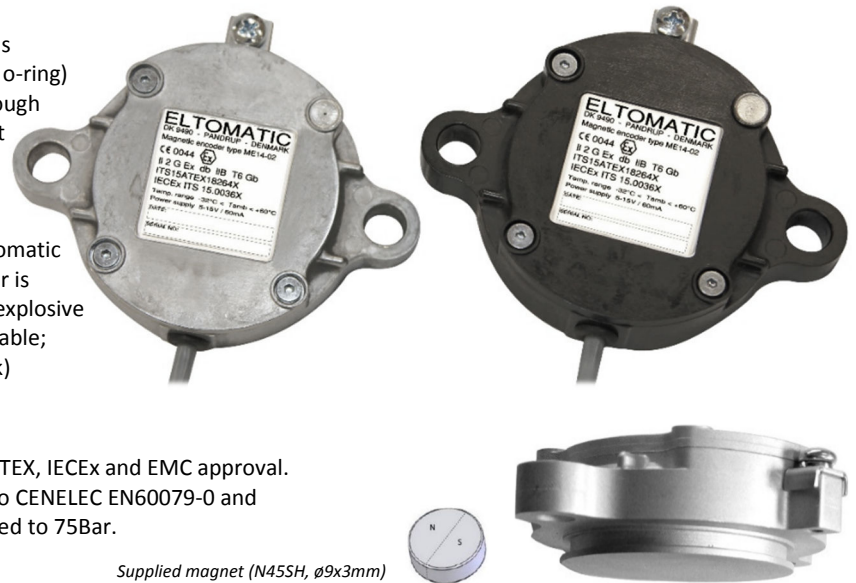

Supplied magnet (N45SH, ø9x3mm)

Specifications

Electrical specifications

Power supply	5 - 15VDC.
Current consumption	Standard 10 to 30mA, max 60mA
Number of channels	1ch., 2ch. or serial output
Number pulses	8 to 1024ppr – both binary and decimal output.
Output signal	Square wave duty cycle 50% ±10%
	Predefined pulse width (one shot)
	CAN-open (optional)
Phase shift	2 channels 90° (25% ±5%)
Output stage	NPN or RS-485
Output current	Max. 30mA
Output frequency	rpm/60 x ppr = ≤1000Hz
Hysteresis	Minimum 0.2°
Temperature range	ATEX approved -32°C to +60°C
Direction of rotation	CW or CCW

Mechanical specifications

Housing	Die cast, aluminum alloy ADC12 or hard anodized (30u) version for AdBlue
RPM	max. 1500 rpm (depending on software)
Sealing	One screw sealed with tin
Labels	Type label
Mounting	With 4 pcs. M4 screws
Weight	Approx. 270g excl. the cable

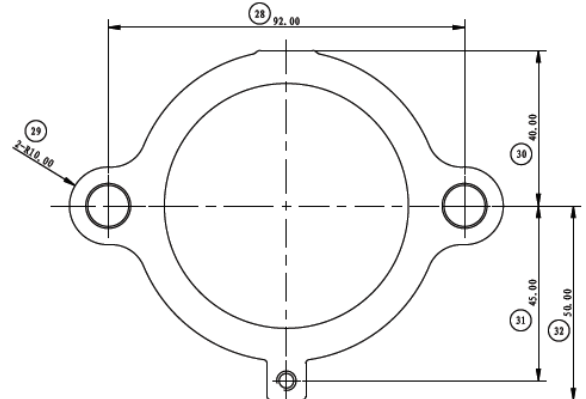
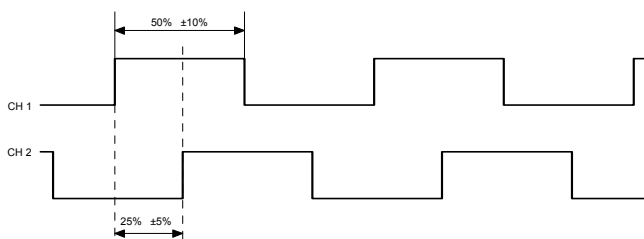

Wiring (standard colour code, customized colour code to be agreed upon)

	Channel 1	Channel 2
Green	VCC	VCC
Brown	GND	GND
White	Ch1	Ch1
Yellow	-	Ch2

Shield is connected internally to the housing

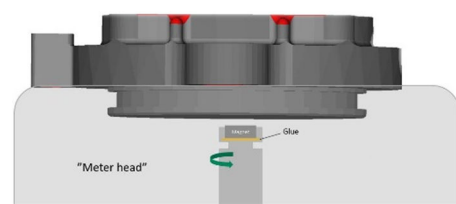

Operating principle shown here mounted on a meter head with preferred magnet-holder solution where max. distance from magnet to encoder is 0.5mm